

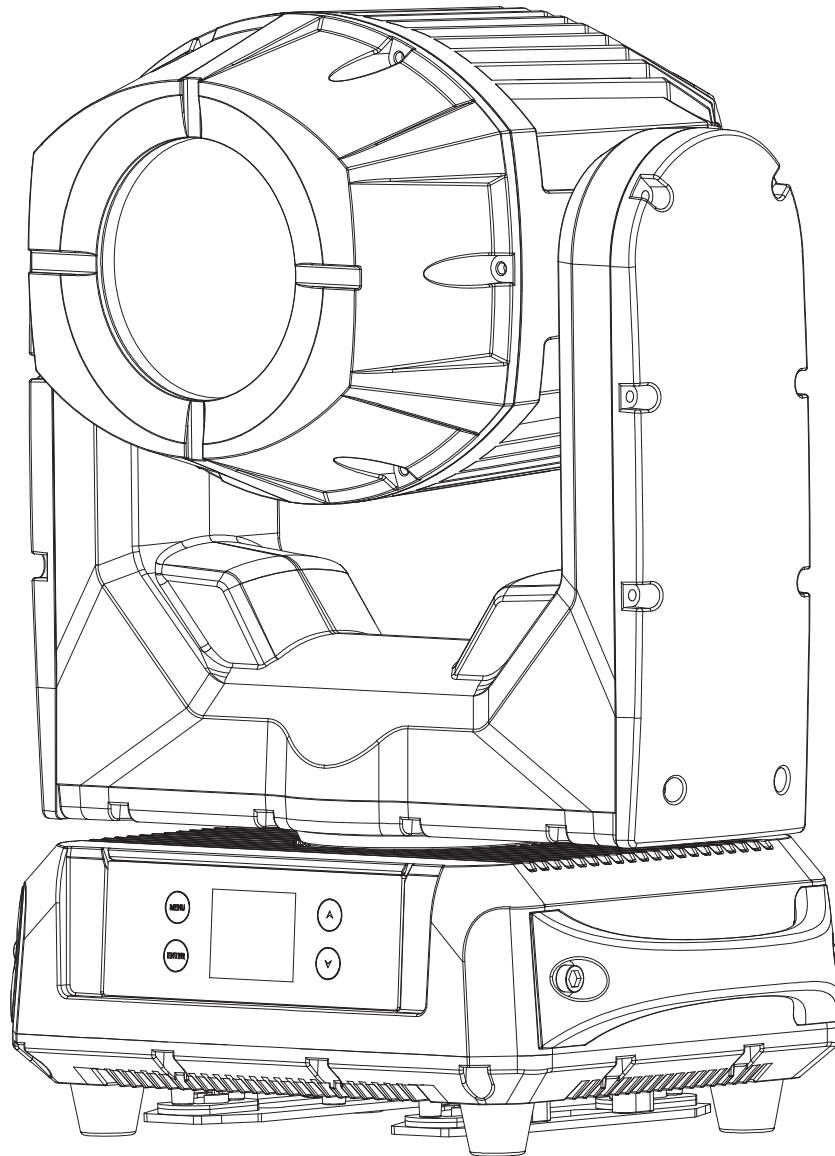

HYDRO BEAM XI



User Instructions

©2019 ADJ Products, LLC all rights reserved. Information, specifications, diagrams, images, and instructions herein are subject to change without notice. ADJ Products, LLC logo and identifying product names and numbers herein are trademarks of ADJ Products, LLC. Copyright protection claimed includes all forms and matters of copyrightable materials and information now allowed by statutory or judicial law or hereinafter granted. Product names used in this document may be trademarks or registered trademarks of their respective companies and are hereby acknowledged. All non-ADJ Products, LLC brands and product names are trademarks or registered trademarks of their respective companies.

ADJ Products, LLC and all affiliated companies hereby disclaim any and all liabilities for property, equipment, building, and electrical damages, injuries to any persons, and direct or indirect economic loss associated with the use or reliance of any information contained within this document, and/or as a result of the improper, unsafe, insufficient and negligent assembly, installation, rigging, and operation of this product.

FCC STATEMENT

This device complies with Part 15 of the FCC Rules. Operation is subject to the following two conditions: (1) this device may not cause harmful interference, and (2) this device must accept any interference received, including interference that may cause undesired operation.

FCC RADIO FREQUENCY INTERFERENCE WARNINGS & INSTRUCTIONS

This product has been tested and found to comply with the limits as per Part 15 of the FCC Rules. These limits are designed to provide reasonable protection against harmful interference in a residential installation. This device uses and can radiate radio frequency energy and, if not installed and used in accordance with the included instructions, may cause harmful interference to radio communications. However, there is no guarantee that interference will not occur in a particular installation. If this device does cause harmful interference to radio or television reception, which can be determined by turning the device off and on, the user is encouraged to try to correct the interference by one or more of the following methods:

- Reorient or relocate the device.
- Increase the separation between the device and the receiver.
- Connect the device to an electrical outlet on a circuit different from which the radio receiver is connected.
- Consult the dealer or an experienced radio/TV technician for help.

DOCUMENT VERSION

Due to additional product features and/or enhancements, an updated version of this document may be available online.

Please check www.adj.com for the latest revision/update of this manual before beginning installation and/or programming.

Date	Document Version	Software Version \geq	DMX Channel Mode	Notes
08/21/19	1	1.0	11 / 14	Initial Version
10/01/19	1.2	N/C	N/C	Software Update Instructions Added
12/17/19	1.3	1.3	N/C	Updated Display Lock/Unlock Feature

Europe Energy Saving Notice

Energy Saving Matters (EuP 2009/125/EC)

Saving electric energy is a key to help protecting the environment. Please turn off all electrical products when they are not in use. To avoid power consumption in idle mode, disconnect all electrical equipment from power when not in use. Thank you!

Introduction	3
Features Warranty Registration	4
IP65 Notice	5
Safety Guidelines	6
Overview	10
Discharge Lamp Warning	11
Lamp Installation	13
Torque Settings & IP Tester	15
Screw Locations	16
Fixture Installation	17
Connections	20
DMX Set Up	21
DMX Addressing	23
DMX Channel Modes	24
Gobos	25
System Menu	26
WiFly Control	33
Error Codes	35
Dimensional Drawings	36
Updating the Software	37
Power Linking Cleaning	38
Limited Warranty (USA Only)	39
Technical Specifications	40

Unpacking: Thank you for purchasing the Hydro Beam X1 by ADJ Products, LLC. Every Hydro Beam X1 has been thoroughly tested and has been shipped in perfect operating condition. Carefully check the shipping carton for damage that may have occurred during shipping. If the carton appears to be damaged, carefully inspect your fixture for any damage and be sure all accessories necessary to operate the unit has arrived intact. In the case damage has been found or parts are missing, please contact our toll free customer support number for further instructions. Do not return this unit to your dealer without first contacting customer support.

Introduction: The ADJ Hydro Beam X1 is a DMX intelligent, IP rated, high powered, moving head fixture. To optimize the performance of this product, please read these operating instructions carefully to familiarize yourself with the basic operations of this unit. ***This product is intended to be used by professionally trained personnel only and is not suitable for private use.***

These instructions contain important safety information regarding the use and maintenance of this unit. Please keep this manual with the unit, for future reference.

Customer Support: Contact ADJ Service for any product related service and support needs. Also visit forums.adj.com with questions, comments or suggestions.

Parts: To purchase parts online visit:

<http://parts.adj.com> (US)

<http://www.adjparts.eu> (EU)

ADJ SERVICE USA - Monday - Friday 8:00am to 4:30pm PST

Voice: 800-322-6337 | Fax: 323-832-2941 | support@adj.com

ADJ SERVICE EUROPE - Monday - Friday 08:30 to 17:00 CET

Voice: +31 45 546 85 60 | Fax: +31 45 546 85 96 | support@adj.eu

ADJ PRODUCTS LLC USA

6122 S. Eastern Ave. Los Angeles, CA. 90040

323-582-2650 | Fax 323-532-2941 | www.adj.com | info@adj.com

ADJ SUPPLY Europe B.V

Junostraat 2 6468 EW Kerkrade, The Netherlands

+31 (0)45 546 85 00 | Fax +31 45 546 85 99

www.adj.eu | info@adj.eu

ADJ PRODUCTS GROUP Mexico

AV Santa Ana 30 Parque Industrial Lerma, Lerma, Mexico 52000

+52 (728) 282-7070

Caution! There are no user serviceable parts inside this unit. Do not attempt any repairs yourself, doing so will void your manufactures warranty. In the unlikely event your unit may require service please contact ADJ Products, LLC.

PLEASE recycle the shipping carton when ever possible.

- IP65 Outdoor Rated
- Electronic Dimming 0-100%
- DMX-512 protocol
- IP65 Locking 5-Pin XLR Connector In & Out
- Multiple DMX Modes
- IP65 Locking Power Connector In & Out
- Colors: 14 + Open (Including CTB & UV)
- Gobos: 15 Gobos + Open
- Prism: Rotating 16-Facet Circular
- Frost Effect
- Multiple Unit Power Linking (See page 38)

Included:

- 1 x IP65 Locking Power Cable
- 2 x Omega Brackets

The Hydro Beam X1 carries a 2 year limited warranty. Please fill out the enclosed warranty card to validate your purchase. All returned service items whether under warranty or not, must be freight pre-paid and accompany a return authorization (R.A.) number. The R.A. number must be clearly written on the outside of the return package. A brief description of the problem as well as the R.A. number must also be written down on a piece of paper included in the shipping carton. If the unit is under warranty, you must provide a copy of your proof of purchase invoice. You may obtain a R.A. number by contacting our customer support team on our customer support number. All packages returned to the service department not displaying a R.A. number on the outside of the package will be returned to the shipper.

IP65 RATED

An IP rated lighting fixture is one, which is commonly installed in outdoor environments and has been designed with an enclosure that effectively protects the ingress (entry) of external foreign objects such as dust and water. The International Protection (IP) rating system is commonly expressed as "IP" (Ingress Protection) followed by two numbers (i.e. IP65) where the numbers define the degree of protection. The first digit (Foreign Bodies Protection) indicates the extent of protection against particles entering the fixture and the second digit (Water Protection) indicates the extent of protection against water entering the fixture. An IP65 rated lighting fixture is one, which has been designed and tested to protect against the ingress of dust (6) and low-pressure water jets from any direction (5).

MARINE/COASTAL ENVIRONMENT INSTALLATIONS

NOT suitable for marine and/or coastal environment installations. Installing this fixture in a marine and/or coastal environment may cause corrosion and/or excessive wear to the interior and/or exterior components of the fixture. Damages and/or performance issues resulting from installation in a marine and/or coastal environment will void the manufactures warranty and will NOT be subject to any warranty claims and/or repairs.

FOR YOUR OWN PERSONAL SAFETY, PLEASE READ AND UNDERSTAND THIS MANUAL COMPLETELY BEFORE YOU ATTEMPT TO INSTALL OR OPERATE THIS UNIT!

- **THERE ARE NO USER SERVICEABLE PARTS INSIDE THIS UNIT. DO NOT ATTEMPT ANY REPAIRS YOURSELF; DOING SO WILL VOID YOUR MANUFACTURES WARRANTY. DAMAGES RESULTING FROM MODIFICATIONS TO THIS FIXTURE AND/OR THE DISREGARD OF SAFETY INSTRUCTIONS AND GUIDELINES IN THIS MANUAL VOID THE MANUFACTURES WARRANTY AND ARE NOT SUBJECT TO ANY WARRANTY CLAIMS AND/OR REPAIRS.**
- **DO NOT PLUG THE FIXTURE INTO A DIMMER PACK!
NEVER OPEN THIS FIXTURE WHILE IN USE!
UNPLUG POWER BEFORE SERVICING FIXTURE!
NEVER TOUCH THE FIXTURE DURING OPERATION AS IT MAY BE HOT!
KEEP FLAMMABLE MATERIALS AWAY FROM FIXTURE!**
- **ENSURE ALL CONNECTIONS AND END CAPS ARE PROPERLY SEALED WITH A DIELECTRIC GREASE (AVAILABLE AT MOST ELECTRICAL SUPPLIERS) TO PREVENT WATER CORROSION AND/OR ELECTRICAL SHORT CIRCUIT.**
- **IF THE FIXTURE IS EXPOSED TO ENVIRONMENTAL TEMPERATURE CHANGES SUCH AS RELOCATION FROM AN OUTDOOR COLD TO AN INDOOR WARM ENVIRONMENT, DO NOT POWER THE FIXTURE ON IMMEDIATELY. INTERNAL CONDENSATION AS A RESULT OF ENVIROMENTAL TEMPERATURE CHANGE CAN CAUSE INTERNAL FIXTURE DAMAGE. LEAVE THE FIXTURE POWERED OFF UNTIL IT HAS REACHED ROOM TEMPERATURE BEFORE POWERING ON.**
- **NEVER LOOK DIRECTLY INTO THE LIGHT SOURCE! RETINA INJURY RISK - MAY INDUCE BLINDNESS!
SENSITIVE PERSONS MAY SUFFER AN EPILEPTIC SHOCK!**
- Be sure that the local power outlet is compatible with the required voltage for your unit.
- Do not attempt to operate this unit if the power cord has been frayed or broken.
- Do not attempt to remove or break off the ground prong from the electrical cord. This prong is used to reduce the risk of electrical shock and fire in case of an internal short.
- Disconnect from main power before making any type of connection.
- Do not remove the cover under any conditions. There are no user serviceable parts inside.
- Never operate this unit when it's cover is removed.
- Always be sure to mount this unit in an area that will allow proper ventilation. Allow about 6" (15cm) between this device and a wall.
- Do not attempt to operate this unit, if it becomes damaged.
- Always mount this unit in safe and stable matter.
- Power-supply cords should be routed so that they are not likely to be walked on or pinched by items placed upon or against them, paying particular attention to cords at plugs, convenience receptacles, and the point where they exit from the appliance.
- Cleaning -The fixture should be cleaned only as recommended by the manufacturer. See page 38 for cleaning details.
- Heat -This fixture should be situated away from heat sources such as radiators, heat registers, stoves, or other appliances (including amplifiers) that produce heat.
- The fixture should be serviced by qualified service personnel when the appliance does not appear to operate normally or exhibits a marked change in performance.

SAFETY GUIDELINES

To guarantee a smooth operation, it is important to follow all instructions and guidelines in this manual. ADJ Products, LLC is not responsible for injury and/or damages resulting from the misuse of this fixture due to the disregard of the information printed in this manual. Only qualified and/or certified personnel should perform installation of this fixture and only the original rigging parts included with this fixture should be used for installation. Any modifications to the fixture and/or the included mounting hardware will void the original manufactures warranty and increase the risk of damage and/or personal injury.



PROTECTION CLASS 1 - FIXTURE MUST BE PROPERLY GROUNDED

THERE ARE NO USER SERVICEABLE PARTS INSIDE THIS UNIT. DO NOT ATTEMPT ANY REPAIRS YOURSELF; DOING SO WILL VOID YOUR MANUFACTURES WARRANTY. DAMAGES RESULTING FROM MODIFICATIONS TO THIS FIXTURE AND/OR THE DISREGARD OF SAFETY INSTRUCTIONS AND GUIDELINES IN THIS MANUAL VOID THE MANUFACTURES WARRANTY AND ARE NOT SUBJECT TO ANY WARRANTY CLAIMS AND/OR REPAIRS.



**DO NOT PLUG FIXTURE INTO A DIMMER PACK!
NEVER OPEN THIS FIXTURE WHILE IN USE!
UNPLUG POWER BEFORE SERVICING FIXTURE!
NEVER TOUCH FIXTURE DURING OPERATION AS IT MAY BE HOT!
KEEP FLAMMABLE MATERIALS AWAY FROM FIXTURE!**



ENSURE ALL CONNECTIONS AND END CAPS ARE PROPERLY SEALED WITH A DIELECTRIC GREASE (AVAILABLE AT MOST ELECTRICAL SUPPLIERS) TO PREVENT WATER CORROSION AND/OR ELECTRICAL SHORT CIRCUIT.



IF THE FIXTURE IS EXPOSED TO ENVIRONMENTAL TEMPERATURE CHANGES SUCH AS RELOCATION FROM AN OUTDOOR COLD TO AN INDOOR WARM ENVIRONMENT, DO NOT POWER THE FIXTURE ON IMMEDIATELY. INTERNAL CONDENSATION AS A RESULT OF ENVIRONMENTAL TEMPERATURE CHANGE CAN CAUSE INTERNAL FIXTURE DAMAGE. LEAVE THE FIXTURE POWERED OFF UNTIL IT HAS REACHED ROOM TEMPERATURE BEFORE POWERING ON.



**NEVER LOOK DIRECTLY INTO THE LIGHT SOURCE!
RETINA INJURY RISK - MAY INDUCE BLINDNESS!
SENSITIVE PERSONS MAY SUFFER AN EPILEPTIC SHOCK!**

SAFETY GUIDELINES

⚠ CAUTION

**HIGH
INTENSITY
ULTRAVIOLET
LIGHT**



AVOID DIRECT EYE & SKIN EXPOSURE.
WEAR PROPER EYE & SKIN PROTECTION.
SEE MANUAL FOR SAFETY INSTRUCTIONS.

RISK GROUP 3 - RISK OF EXPOSURE TO ULTRAVIOLET UV RADIATION! FIXTURE EMITS HIGH INTENSITY WAVELENGTH OF ULTRAVIOLET UV LIGHT FROM THE UV COLOR FILTER. WEAR PROPER EYE AND SKIN PROTECTION. AVOID PROLONGED PERIODS OF EXPOSURE TO UV COLOR FILTER. AVOID WEARING WHITE COLOR CLOTHING AND/OR USING UV PAINTS ON SKIN. AVOID DIRECT EYE AND/OR SKIN

EXPOSURE AT DISTANCES LESS THAN 11 feet (3.3m). DO NOT OPERATE FIXTURE WITH DAMAGED/MISSING EXTERNAL COVERS. DO NOT LOOK DIRECTLY INTO THE UV LIGHT AND/OR VIEW UV LIGHT DIRECTLY WITH OPTICAL INSTRUMENTS THAT MAY CONCENTRATE THE LIGHT/RADIATION OUTPUT. INDIVIDUALS SUFFERING FROM A RANGE OF EYE CONDITIONS, SUNLIGHT EXPOSURE DIS-ORDERS, OR INDIVIDUALS USING PHOTSENSITIVE MEDICATION, MAY RECEIVE DISCOMFORT IF EXPOSED TO THE ULTRAVIOLET UV LIGHT EMITTED FROM THE UV LED.

DO NOT TOUCH the fixture housing during operation. Turn OFF the power and allow approximately 60 minutes for the fixture to cool down before servicing.

DO NOT shake fixture; avoid brute force when installing and/or operating fixture.

DO NOT operate fixture if the power cord has become frayed, crimped, damaged and/or if any of the power cord connectors are damaged and do not insert into the fixture securely with ease.

NEVER force a power cord connector into the fixture. If the power cord or any of its connectors are damaged, replace it immediately with a new one of similar power rating.

DO NOT block any air ventilation slots; these must remain clean and never blocked.

Allow approx. 6" (15cm) between fixture and other devices or a wall for proper cooling.

When installing fixture in a suspended environment, always use mounting hardware that is no less than M10 x 25 mm, and always attach an appropriately rated safety cable.

ALWAYS disconnect fixture from main power source before performing any type of service and/or cleaning procedure. Only handle the power cord by the plug end; never pull out the plug by tugging the wire portion of the cord.

During the initial operation of this fixture, a light smoke or smell may emit from the interior of the fixture. This is a normal process and is caused by excess paint in the interior of the casing burning off from the heat associated with the lamp and will decrease gradually over time.

Consistent operational breaks will ensure fixture will function properly for many years.

ONLY use the original packaging and materials to transport the fixture in for service.

POTENTIAL INTERNAL FIXTURE DAMAGE FROM EXTERNAL SOURCES OF LIGHT BEAMS

External sources of light beams from direct sunlight, lighting moving head fixtures, and lasers, which are focused directly towards the exterior housing and/or penetrate the front lens opening of ADJ lighting fixtures, can cause severe internal damage including burning to optics, dichroic color filters, glass and metal gobos, prisms, animation wheels, frost filters, iris, shutters, motors, belts, wiring, discharge lamps, and LEDs.

This issue is not specific only to ADJ lighting fixtures, it is a common issue with lighting fixtures from all manufacturers. Although there is no true way to fully prevent this issue from happening, the guidelines below can prevent any potential damage from occurring if followed. Contact ADJ Service for more details.

DO NOT EXPOSE THE FIXTURE AND/OR FRONT LENS OPENING TO LIGHT BEAMS FROM DIRECT SUNLIGHT, OTHER LIGHTING MOVING HEAD FIXTURES, AND LASERS WHILE UNPACKING, INSTALLATION, USE, AND EXTENDED IDLE TIMES OUTDOORS.

DO NOT FOCUS A LIGHT BEAM FROM ONE LIGHTING FIXTURE DIRECTLY TOWARDS ANOTHER.

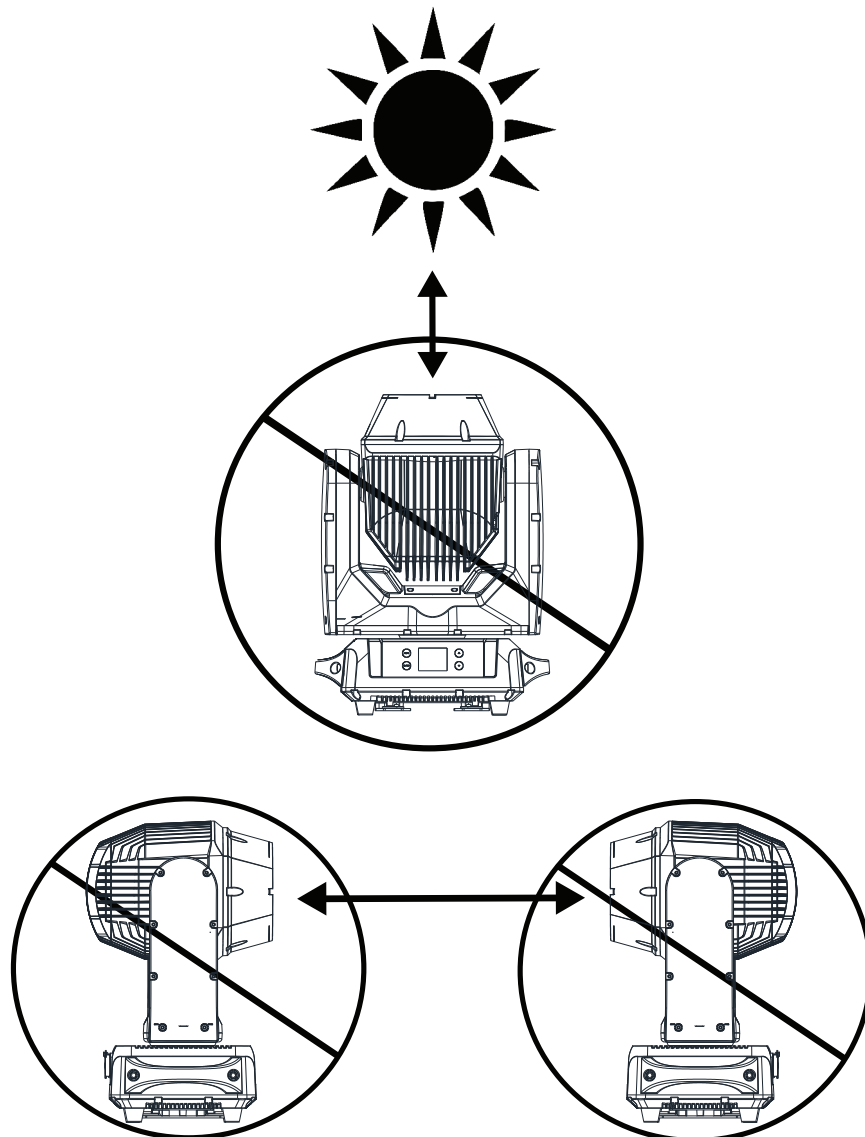

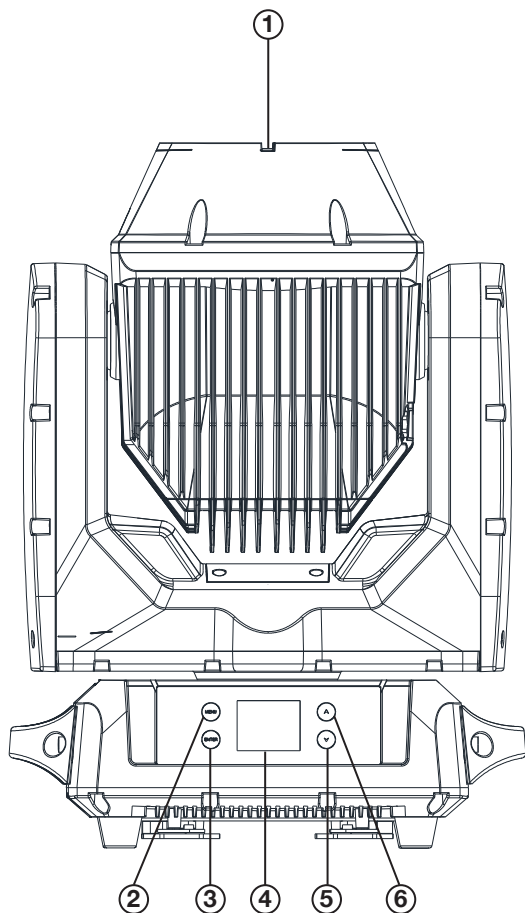

- 1. Lens
- 2. MENU Button
- 3. ENTER Button
- 4. LCD Menu Control Display
- 5. DOWN Button
- 6. UP Button

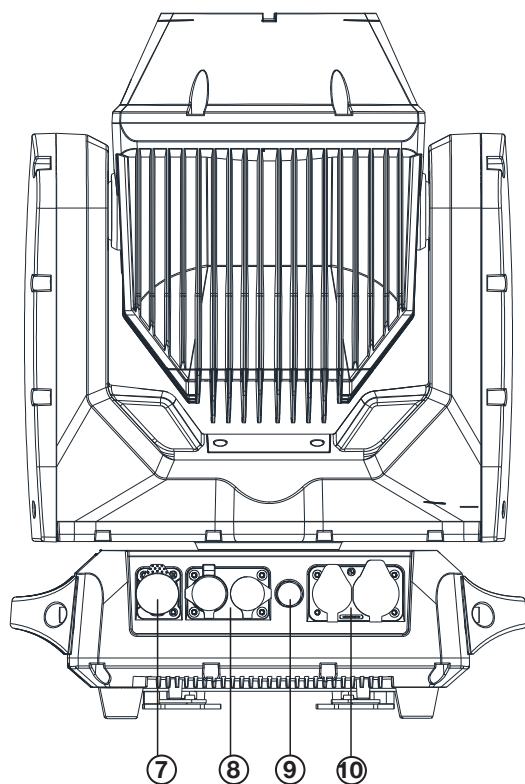

- 7. Service Port
- 8. IP65 Locking 5-Pin XLR Connectors In/Out
- 9. Gore Valve
- 10. IP65 Locking Power Connectors In/Out

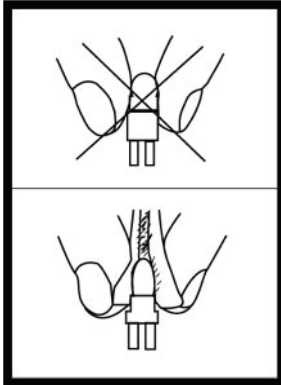
DISCHARGE LAMP WARNING

This fixture is fitted with a **DISCHARGE LAMP**, which is highly susceptible to damage if improperly handled. **NEVER** touch the lamp with your bare hands as the oil from your hands will shorten the life of the lamp. Also, **NEVER** move the fixture until the lamp has had ample time to cool. Lamps are **NOT** covered under warranty conditions. Avoid switching the fixture **ON** and **OFF** repeatedly in short intervals as this will reduce lamp life and intensity. To achieve the intensity associated with discharge lamps, these lamps use gas sealed in a high-pressure environment to emit a brilliant output.

Due to the high pressure involved with the construction of the lamp, the lamp **MAY EXPLODE DURING PROLONGED EXTENSIVE USE**. This risk is increased with age; added care is encouraged when dealing with older lamps. Thus, the lamp must always be replaced at the end of their recommended duty cycle. Extreme caution should be used when operating this or any fixture fitted with a gas discharge lamp.

**U V R A D I A T I O N N O T I C E**

This fixture emits intense **UV** radiation, which is harmful to the eyes and skin. The intense luminance of the lamp can cause severe damage to the retina. **NEVER** operate this fixture with **ANY** of the protective covers removed. These covers have been specially designed to shield against **UV** radiation.

LAMP REPLACEMENT WARNING

When the lamp reaches **5700** Hours of usage, the display will flash the message “**Replace lamp soon**”. This message will flash for up to 10 minutes. To confirm this warning and return to normal operation, press the **ENTER** button.

When the lamp reaches **6000** Hours of usage, the display will flash the message “**Replace lamp now**”. This message will flash for up to 10 minutes. To confirm this warning and return to normal operation, press the **ENTER** button. **NOTE: When the fixture is powered OFF and then back ON again, the fixture display will flash the following message: “Replace LampNow”.**

When the lamp reaches **6200** Hours of usage, the display again will flash the message “**Replace lamp now**”. The unit will now **NO** longer respond to DMX commands and enter hibernation mode which will discontinue all fixture functionality with the exception of a few menu commands. The fixture will continue to enter into hibernation mode until the lamp is replaced and the lamp time (**LAMP ON TIME-R**) has been reset. See page 31 “**LAMP ON TIME-R**” under the “**TOTAL LAMP TIME**” submenu.

NOTE: After replacing the lamp, the lamp time MUST be reset. The lamp time must be reset to gain access to the full system menu.



Lamp Life may vary depending on several factors including but not limited to: Environmental Conditions, Power/Voltage, Usage Patterns (On-Off Cycling), Control, and Dimming.

LAMP INSTALLATION/REPLACEMENT

⚠ WARNING! LAMP REPLACEMENT SHOULD ONLY BE DONE BY A TRAINED TECHNICIAN.

1. Turn OFF power and allow approximately 60 minutes for the fixture to cool down.

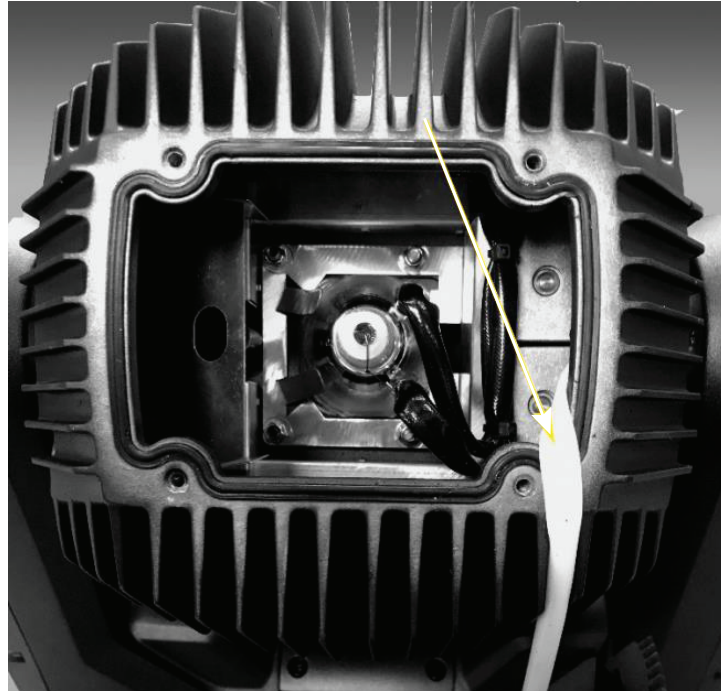

2. Unscrew the (4x) allen head screws to remove the rear cover. When removing the rear cover, please be advised that the cover is connected to the unit via a safety cable and connected wire cable.

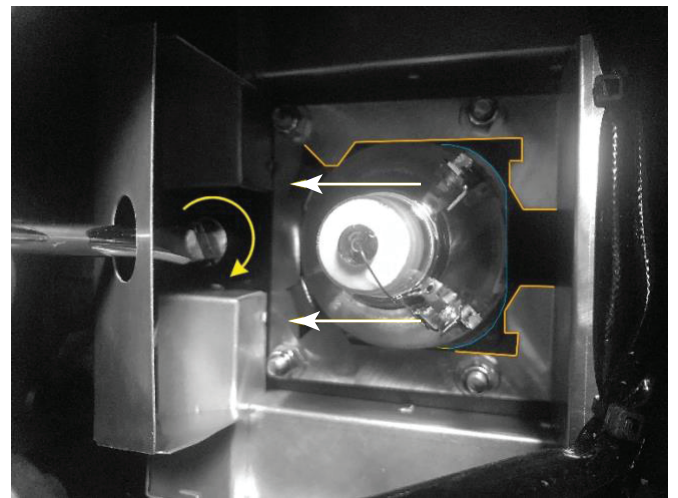
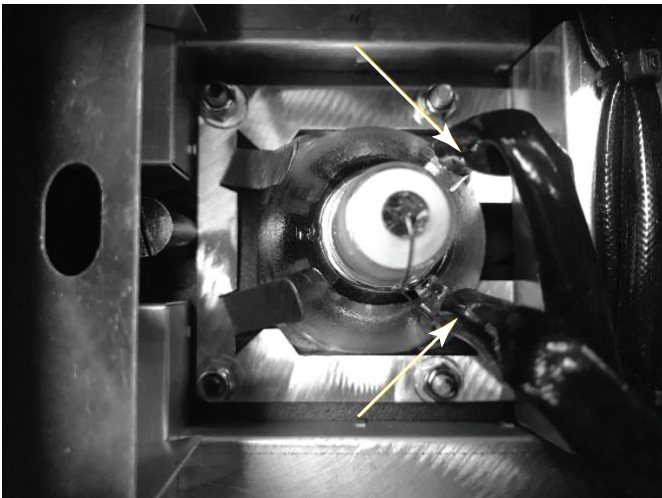

3. Gently remove the (2x) spade terminals connected to the lamp.

4. Use a flat head screwdriver to turn the lamp centering screw clockwise until the lamp slides out of its holding mechanism on the right side.

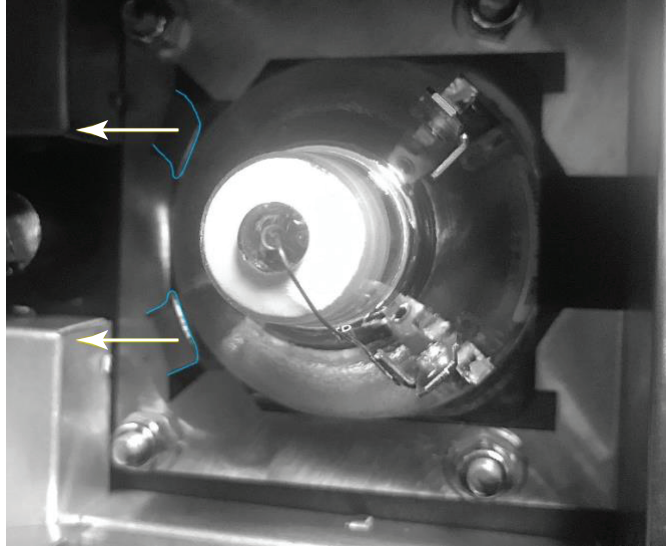

5. Using your fingers, gently pull back the 2 lamp holders, and carefully slide the lamp to the right and out.
6. Slide the new lamp into its socket by pulling it leftwards against the 2 lamp holders. Use a flat head screwdriver and turn the lamp centering screw counter-clockwise to its original position.
7. Reconnect the (2x) spade terminals to the lamp and replace the cover and tightened the (4x) allen head screws.

TORQUE SETTINGS FOR SCREWS

⚠ ALL SCREWS MUST BE TIGHTENED WITH A TORQUE DRIVER. All screws are Allen Head screws. Please see below for screw locations, screw quantity and torque settings. The number listed in the “#” column corresponds to the location on the fixture. See the fixture diagram and number on the next page for screw location depictions.

#	SCREW LOCATIONS	TORQUE SETTING & TOOL SIZE
1	Lens Assembly to Head Casting (x6)	6.5-8.7 In-Lb / 3mm Hex
2	Lamp Cover to Head Casting (x4)	6.5-8.7 In-Lb / 3mm Hex
3	Yoke Arm Cover to Yoke Frame (8 x Each Side = 16 Total)	6.5-8.7 In-Lb / 3mm Hex
4	Access Cover to Yoke Frame (x4)	Manual Screwdriver / 3mm Hex
5	Handle to Base Casting (2 x Each Side = 4 Total)	Fasten by Air Screwdriver / 5mm Hex
6	Bottom Cover to Base Casting (x12)	6.7-9.6 In-Lb / #2 Phillips
7	Power & Data Connector to Base Casting (x10)	6.5-8.7 In-Lb / #2 Phillips
8	1/4 Turn Adaptor Plate to Bottom Cover (x14)	6.5-8.7 In-Lb / #2 Phillips

TORQUE DRIVERS (Recommended):
UTICA TS-30 (Shown)

ALTERNATIVE DRIVERS:
Proto J6107A
Wiha 28887



⚠ CAUTION! DO NOT OVER TORQUE SCREWS AS THIS CAN CAUSE LEAKAGE ISSUES! TO CONFIRM THE IP65 INTENGRITY AFTER A LAMP REPLACEMENT, TEST THE FIXTURE USING THE ELATION IP TESTER. CONTACT ELATION SERVICE FOR MORE DETAILS.



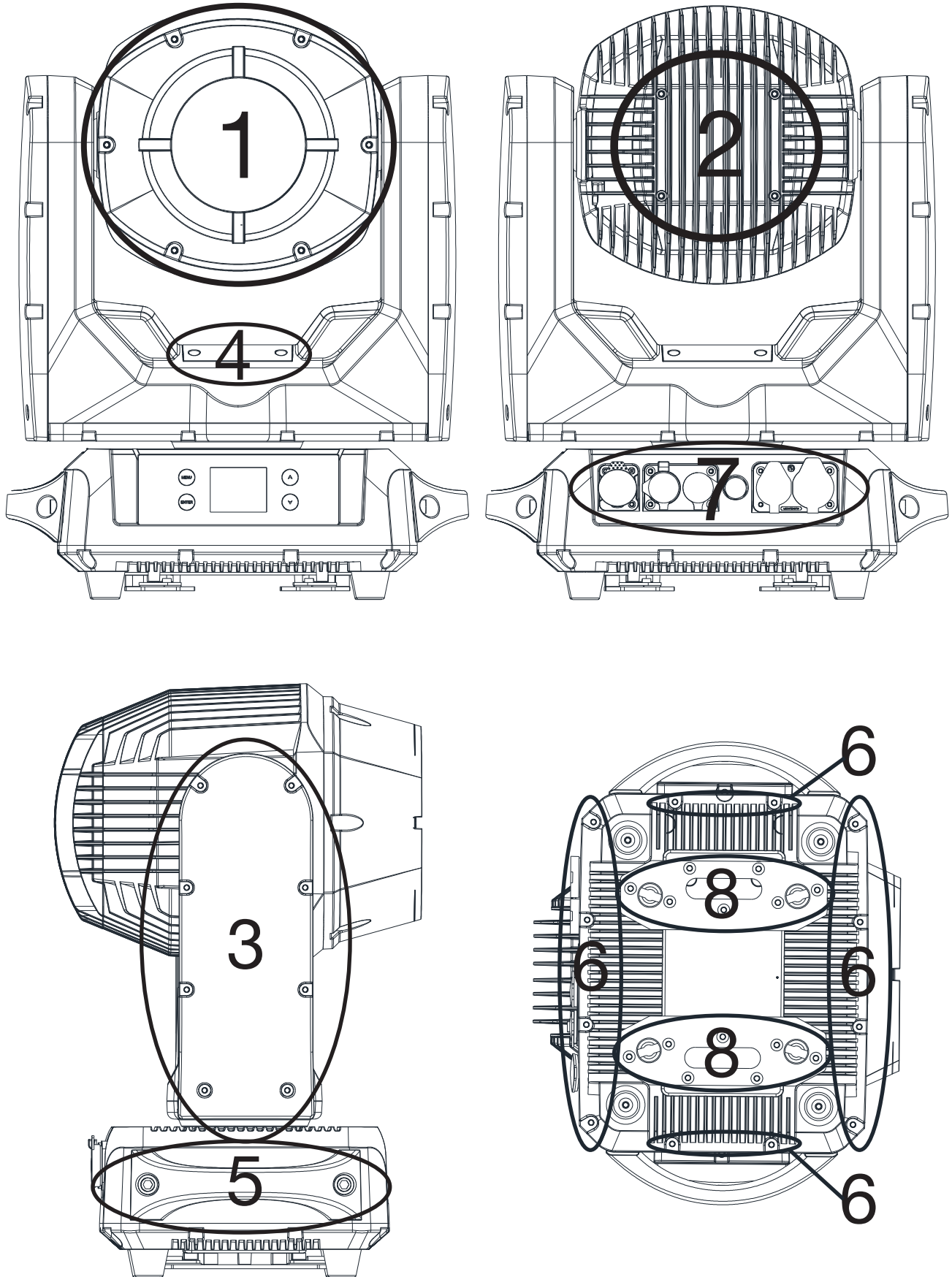

FIXTURE INSTALLATION**FLAMMABLE MATERIAL WARNING**

Keep fixture at least 5.0 feet (1.5m) away from any flammable materials, decorations, pyrotechnics, etc.

**ELECTRICAL CONNECTIONS**

A qualified electrician should be used for all electrical connections and/or installations.



**MINIMUM DISTANCE TO OBJECTS/SURFACES
MUST BE 40 FEET (12 METERS)**



**MAXIMUM TEMPERATURE OF EXTERNAL SURFACE
212° F (100° C)**

DO NOT INSTALL THE FIXTURE IF YOU ARE NOT QUALIFIED TO DO SO!

Fixture **MUST** be installed following all local, national, and country commercial electrical and construction codes and regulations. Before rigging/mounting the fixture to any metal truss/structure or placing the fixture on any surface, a professional equipment installer **MUST** be consulted to determine if the metal truss/structure or surface is properly certified to safely hold the combined weight of the fixture, clamps, cables, and accessories.

Overhead fixture installation must always be secured with a secondary safety attachment, such as an appropriately rated safety cable that meets all local, national, and country codes and regulations.

Fixture ambient operating temperature range is **-4° to 113°F. (-20° to 45°C)**

Do not use this fixture outside this temperature range.

Fixture should be installed in areas outside walking paths, seating areas, or away from areas where unauthorized personnel might reach the fixture by hand.

NEVER stand directly below the fixture when rigging, removing, or servicing.

Allow approximately 60 minutes for the fixture to cool down before servicing.

NOTICE: The suitable environmental temperature for this lighting fixture is between -25°C to 45°C . Do not place this lighting fixture in an environment where the temperatures are under or above the temperatures stated above. This will allow the fixture to run at its best and help prolong the fixture life.

Screw one clamp via a M12 screw and nut into the Omega holder. Insert the quick-lock fasteners of the Omega holder into the respective holes of the adjustable mounting bracket. Tighten the quick-lock fasteners fully clockwise. Pull the safety-cable through the opening(s) located on the bottom of the unit and over the trussing system or a safe fixation spot. Insert the end in the carabine and tighten the safety screw.

CLAMP AND OMEGA BRACKET SET UP

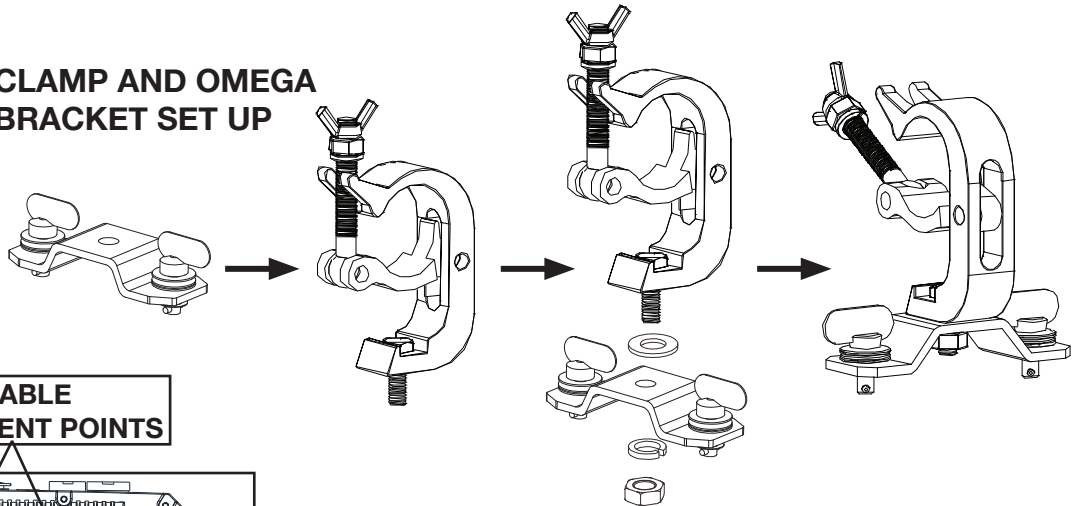

SAFETY CABLE ATTACHMENT POINTS

OMEGA BRACKET ATTACHMENT POINTS

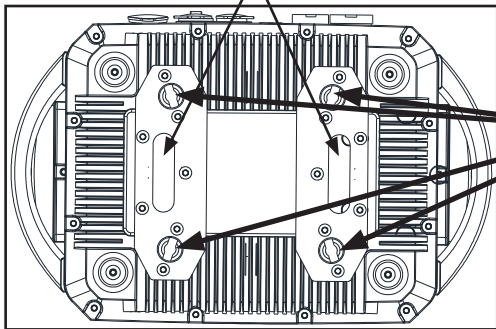

SAFETY CABLE

CLAMP

OMEGA BRACKET

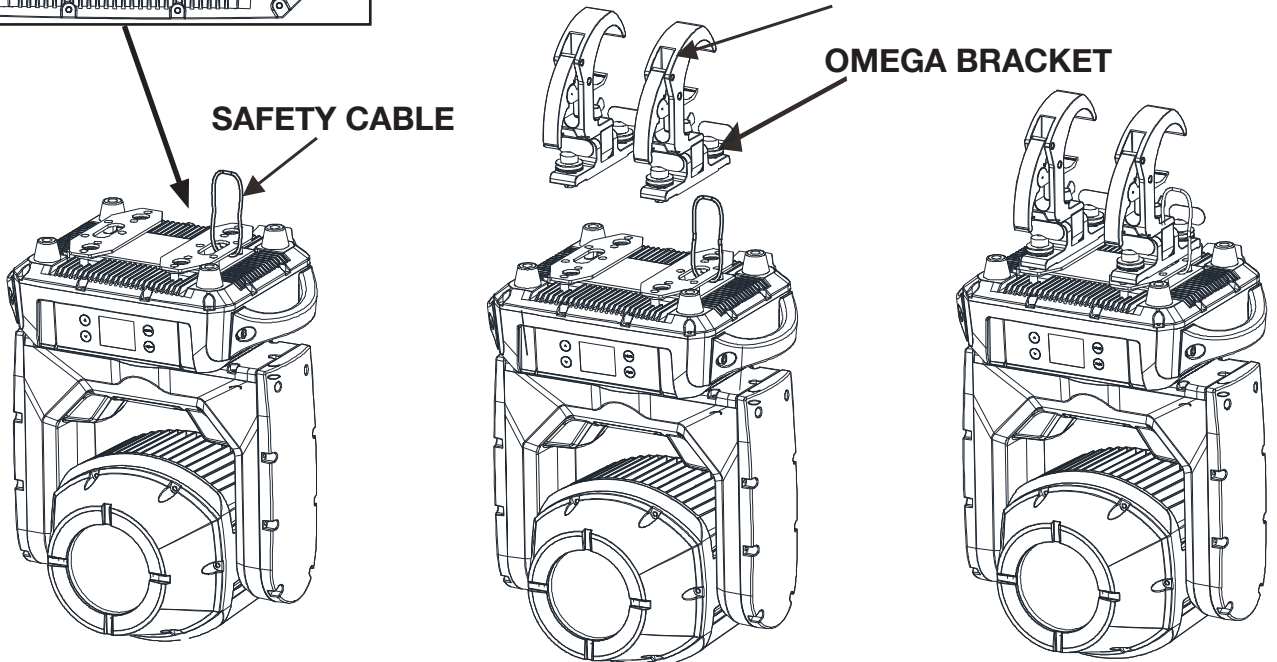

When installing the unit, the trussing or area of installation must be able to hold 10 times the weight without any deformation. When installing the unit must be secured with a secondary safety attachment, e.g. and appropriate safety cable. Never stand directly below the unit when mounting, removing, or servicing the unit.

Overhead mounting requires extensive experience, including calculating working load limits, installation material being used, and periodic safety inspection of all installation material and unit. If you lack these qualifications, do not attempt the installation yourself.

These installation should be checked by a skilled person once a year.

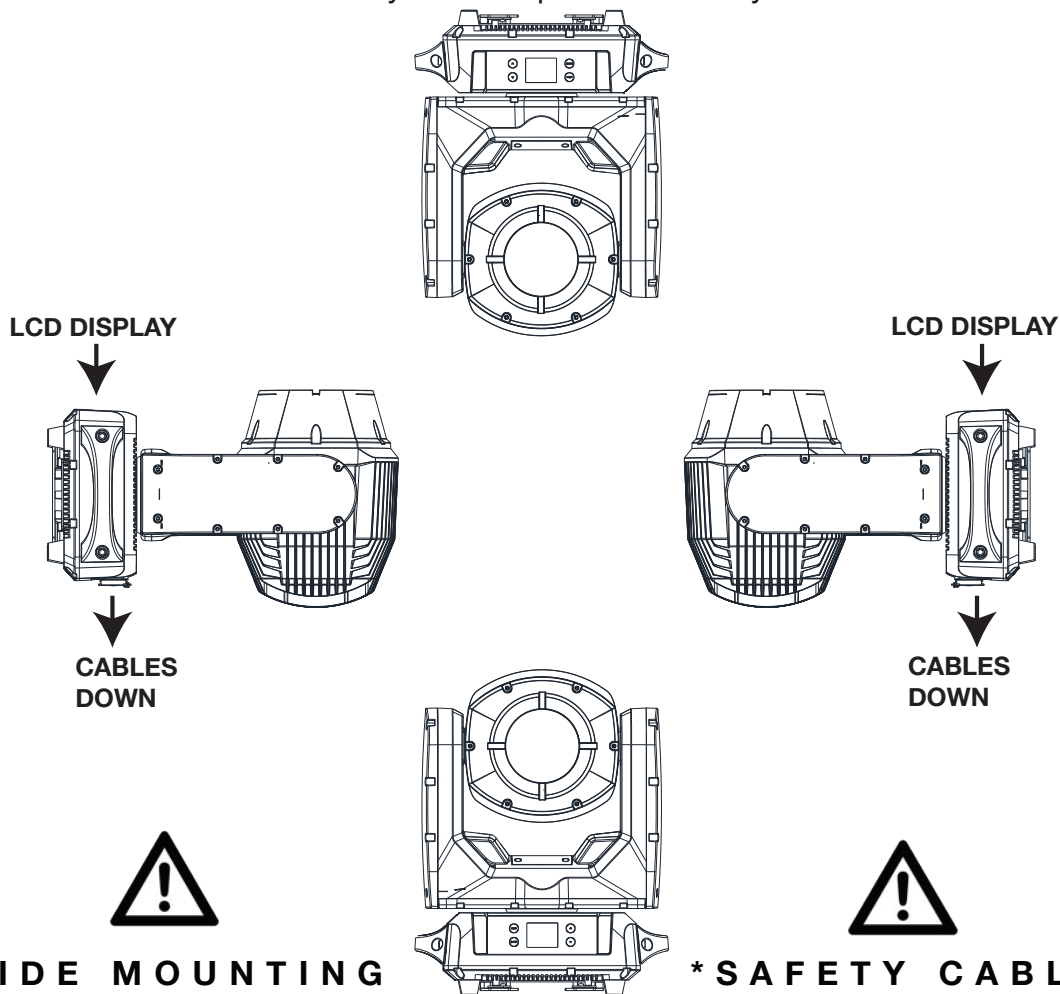

TO MAINTAIN IP65 RATING INTEGRITY, FIXTURE MUST BE INSTALLED WITH CABLES FACING THE GROUND AT ALL TIMES. WATER MUST EASILY RUN OFF AND NOT COLLECT AROUND CABLE CONNECTIONS.

ALWAYS ATTACH A SAFETY CABLE WHENEVER INSTALLING THIS FIXTURE IN A SUSPENDED ENVIRONMENT TO ENSURE THE FIXTURE WILL NOT DROP IF THE CLAMP FAILS.

The Hydro Beam X1 is fully operational in three different mounting positions, hanging upside-down, mounted sideways on trussing, or set on a flat level surface. Be sure this fixture is kept at least 12m (40ft) away from any flammable materials (decoration etc.). Always use and install the supplied safety cable as a safety measure to prevent accidental damage and/or injury in the event the clamp fails (see next page). Never use the carrying handles for secondary attachment.

ENSURE ALL CONNECTIONS AND END CAPS ARE PROPERLY SEALED WITH A DIELECTRIC GREASE (AVAILABLE AT MOST ELECTRICAL SUPPLIERS) TO PREVENT WATER CORROSION AND/OR ELECTRICAL SHORT CIRCUIT.

TO MAINTAIN IP65 RATING INTEGRITY AND PREVENT WATER FROM ENTERING THE FIXTURE, ALL UNUSED CONNECTION RUBBER CAPS MUST BE SEALED.

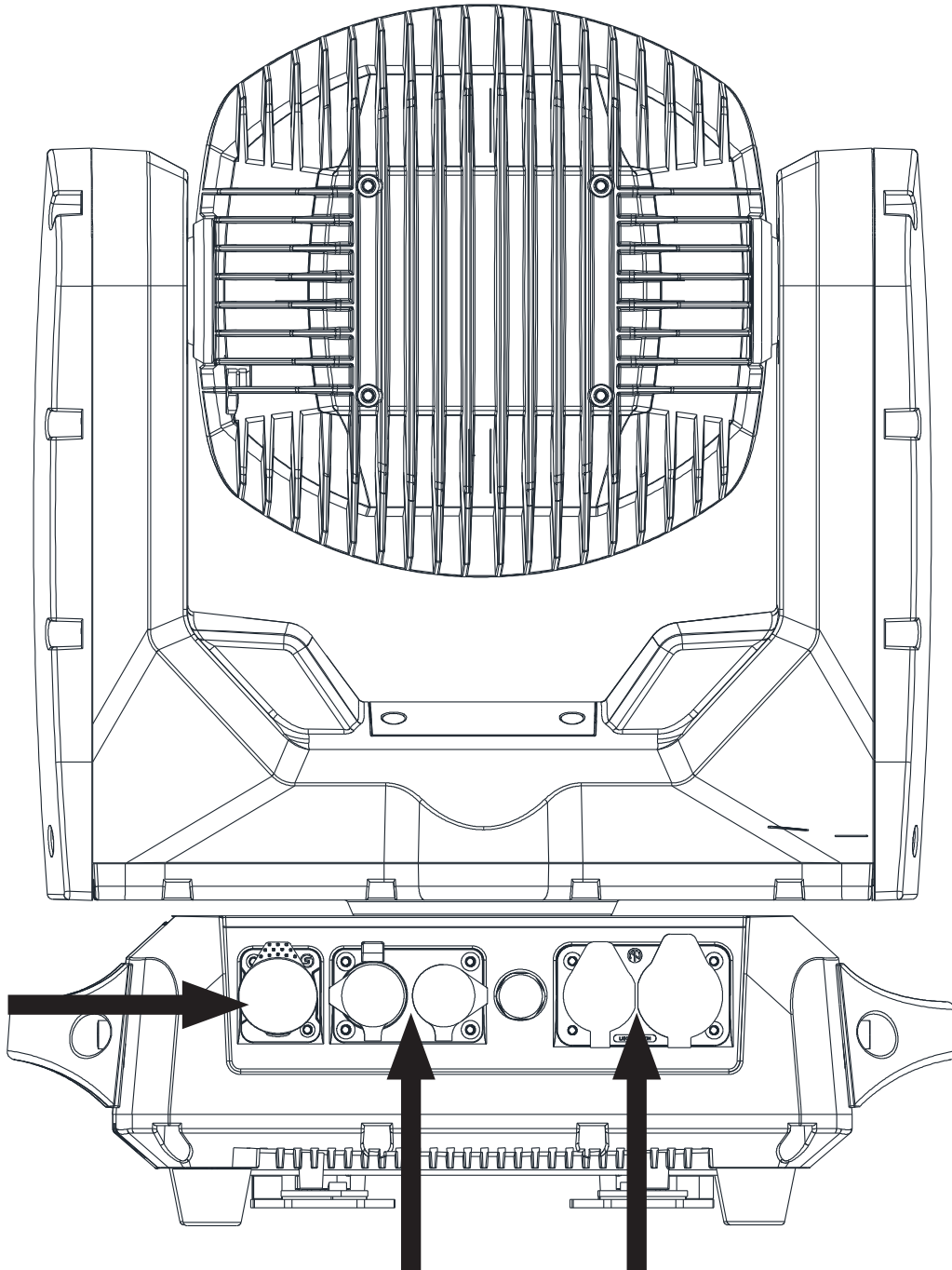

DMX-512: DMX is short for Digital Multiplex. This is a universal protocol used as a form of communication between intelligent fixtures and controllers. A DMX controller sends DMX data instructions from the controller to the fixture. DMX data is sent as serial data that travels from fixture to fixture via the DATA “IN” and DATA “OUT” XLR terminals located on all DMX fixtures (most controllers only have a DATA “OUT” terminal).

DMX Linking: DMX is a language allowing all makes and models of different manufactures to be linked together and operate from a single controller, as long as all fixtures and the controller are DMX compliant. To ensure proper DMX data transmission, when using several DMX fixtures try to use the shortest cable path possible. The order in which fixtures are connected in a DMX line does not influence the DMX addressing. For example; a fixture assigned a DMX address of 1 may be placed anywhere in a DMX line, at the beginning, at the end, or anywhere in the middle. When a fixture is assigned a DMX address of 1, the DMX controller knows to send DATA assigned to address 1 to that unit, no matter where it is located in the DMX chain.

Data Cable (DMX Cable) Requirements (For DMX Operation): The Hydro Beam X1 can be controlled via DMX-512 protocol. Your unit and your DMX controller requires a 5-pin XLR connector for data input and data output. We recommend Accu-Cable DMX cables. If you are making your own cables, be sure to use standard 110-120 Ohm shielded cable (This cable may be purchased at almost all pro lighting stores). Your cables should be made with a male and female XLR connector on either end of the cable. Also remember that DMX cable must be daisy chained and cannot be split.

Special Note: Line Termination. When longer runs of cable are used, you may need to use a terminator on the last unit to avoid erratic behavior. A terminator is a 110-120 ohm 1/4 watt resistor which is connected between pins 2 and 3 of a male XLR connector (DATA + and DATA -). This unit is inserted in the female XLR connector of the last unit in your daisy chain to terminate the line. Using a cable terminator (ADJ part number Z-DMX/T) will decrease the possibilities of erratic behavior.

TO MAINTAIN IP65 RATING INTEGRITY AND PREVENT WATER FROM ENTERING THE FIXTURE, ALL UNUSED CONNECTION RUBBER CAPS MUST BE SEALED AND ONLY IP65 RATED POWER AND DATA CABLES MUST BE USED.

DMX ADDRESSING

All fixtures should be given a DMX starting address when using a DMX controller, so the correct fixture responds to the correct control signal. This digital starting address is the channel number from which the fixture starts to “listen” to the digital control signal sent out from the DMX controller. The assignment of this starting DMX address is achieved by setting the correct DMX address on the digital control display on the fixture.

You can set the same starting address for all fixtures or a group of fixtures, or set different addresses for each individual fixture. Setting all fixtures to the same DMX address will cause all fixtures to react in the same way, in other words, changing the settings of one channel will affect all the fixtures simultaneously.

If you set each fixture to a different DMX address, each unit will start to “listen” to the channel number you have set, based on the quantity of DMX channels of each fixture. That means changing the settings of one channel will only affect the selected fixture.

In the case of the Hydro Beam X1, when in 11 Channel you should set the starting DMX address of the first unit to 1, the second unit to 12 (11 + 1), the third unit to 23 (12 + 11), and so on. (See the chart below for more details.)

Channel Mode	Unit 1 Address	Unit 2 Address	Unit 3 Address	Unit 4 Address
11 Channels	1	12	23	34
14 Channels	1	15	29	43

11 Channels	14 Channels	Values	Functions
1	1	000-255	PAN MOVEMENT (8-BIT): 0°-540°
	2	000-255	PAN FINE (16-BIT): Fine Control of Pan Movement
2	3	000-255	TILT MOVEMENT (8-BIT): 0°-270°
	4	000-255	TILT MOVEMENT (16-BIT): Fine Control of Tilt Movement
3	5		COLOR WHEEL:
		000-002	Open / White
		003-004	White + Red
		005-006	Red
		007-008	Red + Blue
		009-010	Blue
		011-012	Blue + Green
		013-014	Green
		015-016	Green + Yellow
		017-018	Yellow
		019-021	Yellow + Orange
		022-023	Orange
		024-025	Orange + Magenta
		026-027	Magenta
		028-029	Magenta + Light Blue
		030-031	Light Blue
		032-033	Light Blue + Light Yellow
		034-035	Light Yellow
		036-037	Light Yellow + Light Green
		038-039	Light Green
		040-042	Light Green + Purple
		043-044	Purple
		045-046	Purple + Pink
		047-048	Pink
		049-050	Pink + Medium Yellow
		051-052	Medium Yellow
		053-054	Medium Yellow + CTB
		055-056	CTB
		057-058	CTB + UV
		059-060	UV
061-063	UV + White		
064-127	Indexing		
128-189	Clockwise Rotation Fast-Slow		
190-193	Stop		
194-255	Counter-Clockwise Rotation Slow-Fast		

11 Channels	14 Channels	Values	Functions
4	6		GOBO WHEEL:
		000-003	Open
		004-007	Gobo 1
		008-011	Gobo 2
		012-015	Gobo 3
		016-019	Gobo 4
		020-023	Gobo 5
		024-027	Gobo 6
		028-031	Gobo 7
		032-035	Gobo 8
		036-039	Gobo 9
		040-043	Gobo 10
		044-047	Gobo 11
		048-051	Gobo 12
		052-055	Gobo 13
		056-059	Gobo 14
		060-063	Gobo 15
		064-068	Gobo 1 Shake
		069-072	Gobo 2 Shake
		073-076	Gobo 3 Shake
		077-080	Gobo 4 Shake
		081-084	Gobo 5 Shake
		085-089	Gobo 6 Shake
		090-093	Gobo 7 Shake
		094-097	Gobo 8 Shake
		098-101	Gobo 9 Shake
102-105	Gobo 10 Shake		
106-110	Gobo 11 Shake		
111-114	Gobo 12 Shake		
115-118	Gobo 13 Shake		
119-122	Gobo 14 Shake		
123-127	Gobo 15 Shake		
128-189	Counter-Clockwise Rotation Fast-Slow		
190-193	Stop		
194-255	Clockwise Rotation Slow-Fast		
5	7		PRISM (16 FACET CIRCULAR):
		000-007	Close
		008-255	Open
6	8		ROTATING PRISM:
		000-127	Indexing
		128-189	Counter-Clockwise Rotation Fast-Slow
		190-193	Stop
194-255	Clockwise Rotation Slow-Fast		
7	9		SHUTTER & STROBING:
		000-031	Shutter Closed
		032-063	Shutter Open
		064-095	Strobing Slow-Fast
		096-127	Shutter Open
		128-159	Pulse Effect in Sequences
		160-191	Shutter Open
		192-223	Random Strobing Slow-Fast
224-255	Shutter Open		

11 Channels	14 Channels	Values	Functions
8	10	000-255	DIMMER: 0%-100%
	11	000-255	DIMMER FINE: 0%-100%
9	12	000-255	FROST: 0%-100%
10	13	000-255	PAN/TILT MOVEMENT SPEED Fast-Slow
11	14		SPECIAL FUNCTIONS:
		000-069	Null
		070-079	Enable Blackout with Pan/Tilt Movement
		080-089	Disable Blackout with Pan/Tilt Movement
		090-099	Enable Blackout with Color Change
		100-109	Disable Blackout with Color Change
		110-119	Enable Blackout with Gobo Change
		120-129	Disable Blackout with Gobo Change
		130-139	Lamp On
		140-149	Reset Pan/Tilt Motors
		150-159	Reset Effect Motor
		160-199	Null
		200-209	Reset All Motors
		210-229	Null
230-239	Lamp Off		
240-255	Null		



Gobo 1 Gobo 2 Gobo 3 Gobo 4



Gobo 5 Gobo 6 Gobo 7 Gobo 8 Gobo 9



Gobo 10 Gobo 11 Gobo 12 Gobo 13 Gobo 14 Gobo 15

SYSTEM MENU

The fixture includes an easy to navigate system menu control panel display where all necessary settings and adjustments are made. (See image below) During normal operation, pressing the **MENU** button once will access the fixture's main menu. Once in the main menu, you can navigate through the different functions and access the sub-menus with the **UP** and **DOWN** buttons. When you reach a field that requires adjusting, press the **ENTER** button to access that field and use the **UP** and **DOWN** buttons to adjust the field. Pressing the **ENTER** button once more will confirm your setting. You may exit the main menu at any time without making any adjustments by pressing the **MENU** button.

SYSTEM LOCK/UNLOCK: When the display lock function is activated, the display and system menu will lock after 10 seconds of no activity. To UNLOCK the display, press and HOLD the **MENU** button for 10+ seconds.

While pressing the **MENU** button, a timer will appear at the bottom of the display indicating the passing seconds from 0-9. Once the timer reaches 9 seconds, the display will unlock allowing access to the system menu.

DO NOT RELEASE THE MENU BUTTON UNTIL THE DISPLAY IS UNLOCKED.

If the **MENU** button is released before the timer reaches 9 seconds and/or is unlocked, the display will not unlock and the time will be reset.

NOTE: The timer will not appear in the display if the lock function is disabled.

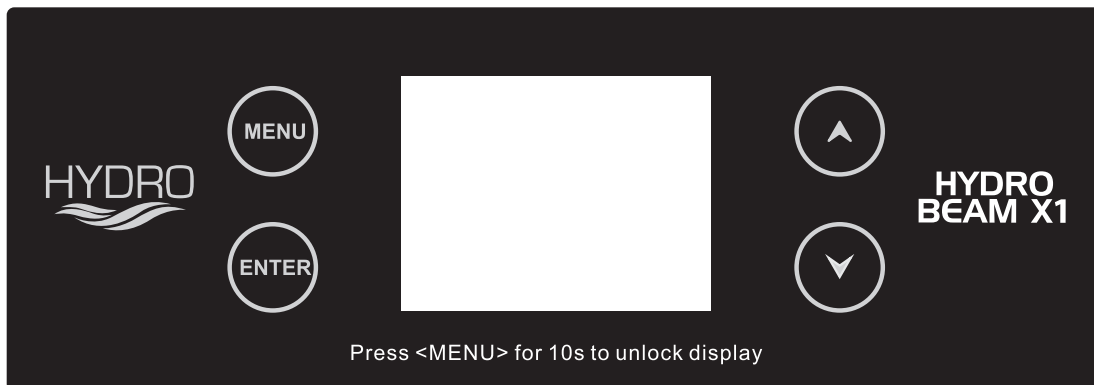

MENU	SUBMENU	OPTIONS	DESCRIPTION
DMX SETTINGS	DMX Address	001-XXX	DMX Addressing
	DMX CH Mode	11Ch / 14Ch	DMX Channel Mode Selection
	No DMX Status	Hold Last / Blackout / Manual	DMX Lost Status
PERSONALITY	Select Signal	DMX	Control via DMX
		WiFly	Control via WiFly
		WiFly and DMX Out	Control via WiFly and send DMX Out via DMX cable
	Status Settings	Pan Invert: On / Off	Reverse Pan Motion
		Tilt Invert: On / Off	Reverse Tilt Motion
		P/T Feedback: On / Off	Pan/Tilt Movement Feedback
		Pan Degree: 540	Pan Degree
		P/T Speed: Speed 1 / Speed 2	Pan/Tilt Movement Speed
		Hibernation: Off / 01M~99M / 15M	Sleep Setting (No Activity)
	WiFly Settings	Set WiFly Channel: 00~14	Set WiFly Wireless Channel
		Enable / Disable WiFly	Activate/Deactivate WiFly
	Reset Motors	Reset All Motors: Yes / No	Reset All Motors
		Pan/Tilt Reset: Yes / No	Reset the Pan & Tilt Motors
		Color Reset: Yes / No	Reset the Color Wheel Motor
		Gobo Reset: Yes / No	Reset the Gobo Wheel Motor
		Prism/R-P Reset: Yes / No	Reset the Prism Motors
		Shutter Reset: Yes / No	Reset the Shutter Motor
		Frost Reset: Yes / No	Reset the Frost Motor
	Display	Intensity: 1~10 (Dimmest-Brightest)	Display Brightness
		Display Invert: Yes / No	Display Readout Inversion
		Screen Saver Delay: Off~10 Minutes	Display Shutoff Time
		Display Lock On/Off: On / Off	Display Lock
	Service (Passcode = 050)	Calibration: Passcode = 050	Calibration Adjustment
		USB Port Power: On / Off	USB Port Activation
		Update Software	Software Update
		Factory Restore: Yes / No - Passcode = 011	Restore Factory Settings
	MANUAL CONTROL	Pan	000-255
Tilt		000-255	
Color		000-255	
Gobo		000-255	
Prism		000-255	
RPrism		000-255	
Shutter		000-255	
Dimmer		000-255	
Frost	000-255		

MENU	SUBMENU	OPTIONS	DESCRIPTION	
INFORMATION	Fixture Life Time	Power On Time: XXXXXX Hours	Total Running Time (Not Resettable)	
		P-On Time-R: XXXXXX Hours	Total Running Time (Resettable)	
		P-On Time Reset: Passcode = 050	Reset P-On Time-R (Total Running Time)	
	Total Lamp Time	Lamp On Time - XXXXXX Hours	Lamp On Time (Not Resettable)	
		Lamp On Time-R: XXXXXX Hours	Lamp On Time (Resettable)	
		Lamp On Time Reset: Passcode = 050	Reset Lamp On Time-R (Lamp On Time)	
	Fixture Temps	Head	Current: XXX °F / XXX °C	Current Head Temperature
			Max Resettable: XXX °F / XXX °C	Maximum Temperature ⁽¹⁾ Reached (Resettable) (See Note 1)
			Max Not Resettable: XXX °F / XXX °C	Maximum Temperature ⁽²⁾ Reached (Not Resettable) (See Note 2)
		Base	Current: XXX °F / XXX °C	Current Base Temperature
			Max Resettable: XXX °F / XXX °C	Maximum Temperature ⁽¹⁾ Reached (Resettable) (See Note 1)
			Max Not Resettable: XXX °F / XXX °C	Maximum Temperature ⁽²⁾ Reached (Not Resettable) (See Note 2)
		Reset Head Temp: Yes / No - Passcode = 050		Reset Head Temperature (Max Resettable)
		Reset Base Temp: Yes / No - Passcode = 050		Reset Base Temperature (Max Resettable)
		Humidity	Head Humidity: XXX%	Current Head Humidity
	Base Humidity: XXX%		Current Base Humidity	
	Fan Info. (RPM)	Lamp Fan: XXX	Lamp Fan Speed	
		Head Fan 1: XXX	Head Fan Speed	
		Head Fan 2: XXX	Head Fan Speed	
		Head Fan 3: XXX	Head Fan Speed	
		Head Fan 4: XXX	Head Fan Speed	
		Base Fan: XXX	Base Fan Speed	
	DMX Values ⁽³⁾ (See Note 3)	Pan / Pan Fine / Tilt / Tilt Fine / Color / Gobo / Prism / RPrism / Shutter / Dimmer / Dimmer Fine / Frost / P/T Speed / Spe. Func	Current DMX Values	
	Error Logs	Fixture Errors (Listed Errors One by One)	Last 10 Fixture Error Codes	
		Reset Error Log: Yes / No (Pass Code = 050)	Clear the Error Log	
	Software Version	VX.XX	Current Software Version	

MENU	SUBMENU	OPTIONS	DESCRIPTION
LAMP CONTROL	Lamp ON / OFF	On / Off	Lamp On/Off
	Lamp ON with Power	On / Off	Lamp ON when Power ON
	Lamp ON via DMX	On / Off	Lamp Power ON via DMX
	Lamp OFF via DMX	On / Off	Lamp Power OFF via DMX

Notes:

- (1) Current Maximum Temperature - Maximum fixture temp. that has been recorded, before reset and after reset.
- (2) Maximum Temperature - Overall maximum fixture temp. that has been recorded. (Not Resettable).
- (3) DMX Value options depend on the DMX Channel mode setting.

System Menu: When making adjustments press **ENTER** to confirm your setup. To exit without making any adjustments press the **MENU** button. The display will lock after 30 seconds, press the **MENU** button for 3 seconds to unlock.

DMX SETTINGS - The submenus listed under **DMX SETTINGS** are as follows: **DMX Address**, **DMX Channel Mode**, **No DMX Status**, and **Select Signal**.

- **DMX ADDRESS** - In this submenu you can use the UP or DOWN buttons to adjust and find your desired DMX address.
- **DMX CHANNEL MODE** - In this submenu you can use the UP or DOWN buttons to find your desired DMX channel mode.
- **NO DMX STATUS** - This submenu setting is used as a precaution mode in case the DMX signal is lost or interrupted. The operating mode chosen in this submenu is the running mode the fixture will go into when the DMX signal is lost. Listed below are the 3 modes.
 - **HOLD LAST** - This setting will have the fixture stay in the last DMX setup.
 - **BLACKOUT** - This setting will have the fixture automatically go into stand by mode.
 - **MANUAL** - This setting will go into the current manual control set up. See **MANUAL CONTROL**.

PERSONALITY - The submenus listed under **PERSONALITY** are as follows: **Select Signal**, **Status Settings**, **WiFly Settings**, **Reset Motors**, **Display**, and **Service**.

- **SELECT SIGNAL** - In this submenu you can select your desired DMX control mode:
 - **DMX** - Control the unit via DMX cable connection.
 - **WiFly** - Control the unit via WiFly.
 - **WiFly / DMX Out** - Control the unit via WiFly connection. The DMX signal is sent to the next unit via DMX cable.
- **STATUS SETTINGS** - In this submenu you are able to access and adjust/change: Pan Invert, Tilt Invert, P./T. Feedback, Pan Degree (no adjustment), P./T. Speed, and Hibernation.
- **WIFLY SETTINGS** - In this submenu you are able to access and adjust/change: WiFly Channel setting and Enable/Disable WiFly.
- **RESET MOTORS** - In this submenu you are able to reset selected motors.
- **DISPLAY** - In this submenu you are able to access and adjust/change: Backlight Intensity, Display Invert, Screen Saver Delay, and Display Lock.
- **SERVICE** - In this submenu you are able to access and adjust/change: calibration setting, USB power activation, update the software, and restore the factory settings.
NOTE: To update the software please see page 37 for more details.

MANUAL CONTROL - This menu is for manual testing and manual control. Pan, tilt, color wheel, gobo wheel, prism, prism rotation, shutter, dimmer, and frost can all be tested/adjusted.

INFORMATION - The submenus listed under **INFORMATION** are as follows: *Fixture Life Time*, *Total Lamp Time*, *Fixture Temps*, *Humidity*, *Fan Info. (RPM)*, *DMX Values*, *Error Logs*, and *Software Version*.

- **FIXTURE LIFE TIME**

- **Power On Time** - The **TOTAL** power ON running time of the unit is displayed. This time **CANNOT** be reset. **Reminder: The displayed time represents the TOTAL POWER ON time.**
- **P-On Time-R** - The **CURRENT** power ON running time of the unit is displayed. This running time may not be the same as the total power ON running time displayed under **"Power On Time"**. This time **CAN** be reset. **Reminder: The displayed time represents the CURRENT POWER ON TIME since the last reset.**
- **P-On Time Reset** - Reset the **CURRENT** power ON running time that is displayed under **"P-On Time-R"**.

- **TOTAL LAMP TIME**

- **Lamp On Time** - The **TOTAL** Lamp ON time is displayed. This total lamp ON time **CANNOT** be reset. **Reminder: The displayed time represents the TOTAL LAMP ON time.**
- **Lamp On Time-R** - The **CURRENT** LED ON running time is displayed. This running time may not be the same as the total lamp ON time displayed under **"Lamp On Time"**. This total lamp ON time **CAN** be reset. **Reminder: The displayed time represents the CURRENT LAMP ON time since the last reset.**
- **Lamp On Time Reset** - With this function you can reset the **CURRENT** lamp ON time that is displayed under **"Lamp On Time-R"**.

- **FIXTURE TEMPS**

• **Head**

Current - Current temperature of the moving head is displayed.

Max Resettable - Maximum moving head temperature that has been recorded, before reset and after reset. **(Resettable)**

Max Not Resettable - Overall maximum moving head temperature that has been recorded. **(Not Resettable)**

• **Base**

Current - Current temperature of the base is displayed.

Max Resettable - Maximum base temperature that has been recorded, before reset and after reset. **(Resettable)**

Max Not Resettable - Overall maximum base temperature that has been recorded. **(Not Resettable)**

- **Reset Head Temp** - Reset the **"MAX RESETTABLE"** moving head temperature. **(Pass Code is "50")**

- **Reset Base Temp** - Reset the **"MAX RESETTABLE"** base temperature. **(Pass Code is "50")**

- **HUMIDITY**

Head Humidity - The current humidity of the moving head is displayed.

- Base Humidity* - The current humidity of the base is displayed.
 - **FAN INFO. (RPM)**
 - Lamp Fan* - Current speed of the LED fan is displayed.
 - Head Fan 1* - Current speed of the moving head fan 1 is displayed.
 - Head Fan 2* - Current speed of the moving head fan 2 is displayed.
 - Head Fan 3* - Current speed of the moving head fan 3 is displayed.
 - Head Fan 4* - Current speed of the moving head fan 4 is displayed.
 - Base Fan* - Current speed of the base fan is displayed.
 - **DMX Values** - Displays the DMX values of any DMX channel that is currently in use.
NOTE: DMX Value options depend on the DMX Channel mode setting.
 - **Error Logs** - Displays any error codes.
 - **Software Version** - Current software version is displayed.
- LAMP CONTROL** - The submenus listed under **LAMP CONTROL** are as follows: **Lamp ON/OFF**, **Lamp ON with Power**, **Lamp ON via DMX**, and **Lamp OFF via DMX**.
- **Lamp ON/OFF** - Turn the lamp On/Off.
 - **Lamp ON with Power** - Lamp powers “ON” when power is applied.
 - **Lamp ON via DMX** - Power lamp “ON” using a DMX controller.
 - **Lamp OFF via DMX** - Power lamp “OFF” using a DMX controller.



BEFORE SETTING THE WIRELESS CHANNEL ON ANY WIFLY FIXTURE, MAKE SURE THE SOURCE WIFLY WIRELESS DMX TRANSCEIVER DEVICE IS OFF.

With this feature you are able to control the unit with DMX without the need of XLR cables. Your DMX controller must be connected to a ADJ WiFly Transceiver to use this function. You are able to communicate up to 2500 feet/760 meters (open line of sight).

1. Ensure the source WiFly wireless DMX Transceiver device is powered OFF.
2. Power **ON** the fixture and using the control panel scroll to the **PERSONALITY** menu and press **ENTER**. Use the **UP** and **DOWN** buttons to highlight the **WIFLY SETTINGS** submenu and press **ENTER**.
3. Using the UP and DOWN buttons, highlight **ENABLE/DISABLE WIFLY**. Press the ENTER button to toggle between **ENABLE & DISABLE**. Press ENTER so that “**ENABLE**” is displayed.
4. Next highlight **SET WIFLY CHANNEL** and press **ENTER**. Use the **UP** and **DOWN** buttons to find your desired WiFly address and press **ENTER** to confirm.

NOTE: Erratic fixture movement may occur if other **WiFly** wireless DMX products are in use in the same area and are using the same **WiFly** wireless channel. When **WiFly** is enabled, the fixture may immediately start to respond to the DMX wireless signal from another **WiFly** wireless DMX Transceiver. Make sure to know what **WiFly** wireless channels are being used in the area where the fixture is being used.

ADJ WIFLY WIRELESS TRANSCEIVER only has 0-14 wireless channels, NO CH 15.

5. Press the **MENU** button to exit out of the **WIFLY SETTINGS** submenu. Press the **UP** button so that **SELECT SIGNAL** is highlighted and press **ENTER**. Press the **DOWN** button to highlight **WIFLY** and press **ENTER**. Select **YES** and press **ENTER** to confirm.
6. Set your desired DMX address in the **DMX ADDRESS** submenu of the **DMX SETTINGS** main system menu. Set your desired DMX channel mode in the **DMX CH MODE** submenu of the **DMX SETTINGS** main system menu.
7. Repeat this process for all **WiFly** compatible fixtures in the **WiFly** wireless network, making sure all fixtures are assigned the same **WiFly** wireless channel.
8. After all fixtures in the **WiFly** wireless network have been set to the same **WiFly** wireless channel and powered ON, power ON the source **WiFly** DMX Transceiver device.
4. Test all fixtures connected to the WiFly wireless network to confirm proper functionality.

WIRELESS WIFLY INSTALLATION LOCATION GUIDELINES

Wireless DMX signal can penetrate walls, glass, metal, and most objects. However, there are many factors that can affect and/or interrupt the wireless DMX signal, one of which is people. Therefore, it is highly recommended to position the wireless antenna a minimum of 9.8 ft. (3m) above audiences and/or above ground level. Careful planning and testing of the selected installation location is critical to ensure optimum and reliable wireless DMX operation.

**9.8 ft (3m)
Above Ground**



	Print error message	Description
1	Lamp Hot Power Off	Lamp Hot Power Off
2	CPU-B Error	CPU-B Error
3	CPU-C Error	CPU-C Error
4	Pan Reset Error	Pan :Reset Error
5	Pan Encoder Error	Pan : Encoder Error
6	Tilt Reset Error	Tilt :Reset Error
7	Tilt Encoder Error	Tilt : Encoder Error
8	Color Reset Error	Color :Reset Error
9	Gobo Reset Error	Gobo :Reset Error
10	Lamp Fan 1 start Errors	LampFan 1 Can't Start
11	Lamp Fan 1 stop Errors	Lamp Fan 1 Can't Stop
12	Head Fan 1 start Errors	Head Fan 1 Can't Start
13	Head Fan 1 stop Errors	Head Fan 1 Can't Stop
14	Head Fan 2 start Errors	Head Fan 2 Can't Start
15	Head Fan 2 stop Errors	Head Fan 2 Can't Stop
16	Head Fan 3 start Errors	Head Fan 3 Can't Start
17	Head Fan 3 stop Errors	Head Fan 3 Can't Stop
18	Head Fan 4 start Errors	Head Fan 4 Can't Start
19	Head Fan 4 stop Errors	Head Fan 4 Can't Stop
20	Base Fan 1 start Errors	Base Fan 1 Can't Start
21	Base Fan 1 stop Errors	Base Fan 1 Can't Stop
22	Base Fan 2 start Errors	Base Fan 2 Can't Start
23	Base Fan 2 stop Errors	Base Fan 2 Can't Stop

***NOT TO SCALE**

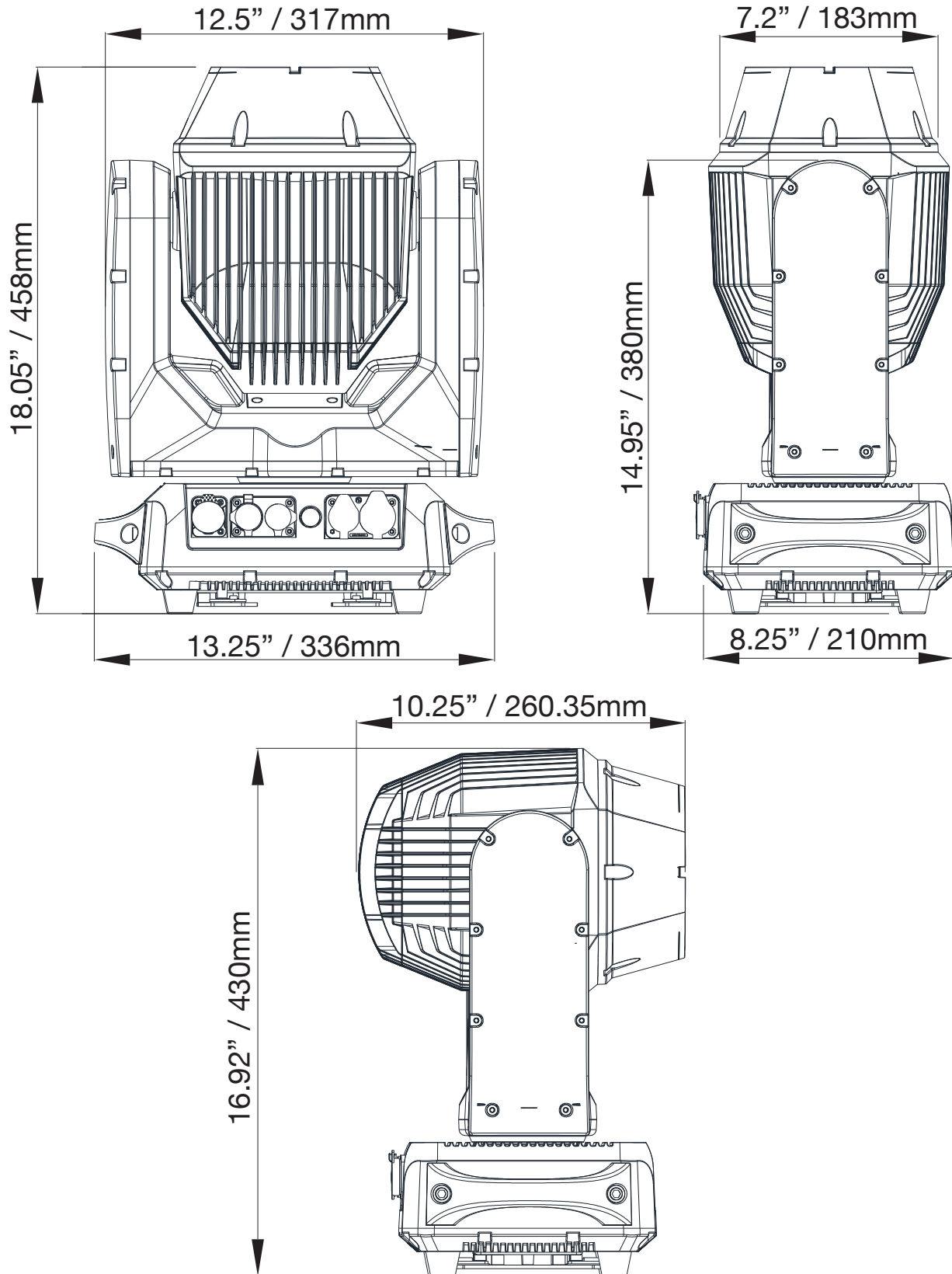



**ONLY QUALIFIED TECHNICIANS SHOULD PERFORM THIS FUNCTION!
NOTE ALL MENU SETTINGS BEFORE UPDATING SOFTWARE!
FIXTURE SOFTWARE CAN NOT BE DOWNGRADED!
DOWNLOAD FIXTURE SOFTWARE TO PC ONLY! (NO MAC SUPPORT)
PLEASE CONTACT ADJ CUSTOMER SERVICE FOR FURTHER INFORMATION.**

1. Contact ADJ Customer Service to obtain the software update files.
2. Copy the software files to a compatible USB flash drive.
NOTE: MAKE SURE THESE SOFTWARE FILES ARE THE ONLY FILES LOADED ONTO THE USB FLASH DRIVE.
3. Disconnect DMX and WiFly connections and power the fixture ON.
4. Insert the USB flash drive into the **SERVICE PORT** located on the rear panel of the unit.
5. Locate **PERSONALITY** within the system menu and press **ENTER**. Scroll to the **SERVICE** submenu and press **ENTER**. Enter the passcode **50** to gain access.
6. Scroll to the **USB PORT POWER** setting and activate the USB service port by selecting **ON**.
NOTE: The USB port is OFF by default.
7. After activating the USB port, scroll to **UPDATE SOFTWARE** and press **ENTER**.
8. Two (2) software files will be displayed as downloaded earlier. Highlight the first file and press **ENTER**. Select **YES** to begin the first of two updating processes. Once **YES** is selected the display will show **Updating, Please wait...**. A percentage bar will also be displayed.
9. After the first update is complete, the fixture will run a software check (this can take some time).
10. After the software check is complete, the fixture will perform a reset.
11. Once the reset is complete, scroll to the **PERSONALITY** menu again and press **ENTER**. Scroll to the **SERVICE** submenu and press **ENTER**. Enter the passcode **50** to gain access.
12. Reactivate the USB port power if necessary. **(See step 6)**
13. Scroll to **UPDATE SOFTWARE** setting again and press **ENTER**.
14. Highlight the second file this time and press **ENTER**. Select **YES** to begin the second and final updating process. Once **YES** is selected the display will show **Updating, Please wait...**. A percentage bar will also be displayed.
15. After the second update is complete, the fixture will run a software check again.
16. After the software check is complete, the fixture will perform another reset.
17. Remove the USB flash drive.
18. After the reset process is complete check the new software version to confirm it is updated to the most recent software.

With this feature you can connect the fixtures to one another using the power cable input and output sockets.

NOTE: USE CAUTION WHEN POWER LINKING OTHER FIXTURES AS THE POWER CONSUMPTION OF OTHER MODEL FIXTURES MAY EXCEED THE MAX POWER OUTPUT ON THIS FIXTURE! CHECK SILK SCREEN FOR MAX AMPS.

Due to fog residue, smoke, and dust cleaning the internal and external optical lenses must be carried out periodically to optimize light output.

1. Use normal glass cleaner and a soft cloth to wipe down the outside casing.
2. Clean the external optics with glass cleaner and a soft cloth every 20 days.
3. Always be sure to dry all parts completely before plugging the unit back in.

Cleaning frequency depends on the environment in which the fixture operates (i.e. smoke, fog residue, dust, dew).

MANUFACTURER'S LIMITED WARRANTY

- A. ADJ Products, LLC hereby warrants, to the original purchaser, ADJ Products, LLC products to be free of manufacturing defects in material and workmanship for a prescribed period from the date of purchase (see specific warranty period on reverse). This warranty shall be valid only if the product is purchased within the United States of America, including possessions and territories. It is the owner's responsibility to establish the date and place of purchase by acceptable evidence, at the time service is sought.
- B. For warranty service you must obtain a Return Authorization number (RA#) before sending back the product—please contact ADJ Products, LLC Service Department at 800-322-6337. Send the product only to the ADJ Products, LLC factory. All shipping charges must be pre-paid. If the requested repairs or service (including parts replacement) are within the terms of this warranty, ADJ Products, LLC will pay return shipping charges only to a designated point within the United States. If the entire instrument is sent, it must be shipped in its original package. No accessories should be shipped with the product. If any accessories are shipped with the product, ADJ Products, LLC shall have no liability whatsoever for loss of or damage to any such accessories, nor for the safe return thereof.
- C. This warranty is void if the serial number has been altered or removed; if the product is modified in any manner which ADJ Products, LLC concludes, after inspection, affects the reliability of the product; if the product has been repaired or serviced by anyone other than the ADJ Products, LLC factory unless prior written authorization was issued to purchaser by ADJ Products, LLC; if the product is damaged because not properly maintained as set forth in the instruction manual.
- D. This is not a service contract, and this warranty does not include maintenance, cleaning or periodic check up. During the period specified above, ADJ Products, LLC will replace defective parts at its expense with new or refurbished parts, and will absorb all expenses for warranty service and repair labor by reason of defects in material or workmanship. The sole responsibility of ADJ Products, LLC under this warranty shall be limited to the repair of the product, or replacement thereof, including parts, at the sole discretion of ADJ Products, LLC. All products covered by this warranty were manufactured after August 15, 2012, and bear identifying marks to that effect.
- E. ADJ Products, LLC reserves the right to make changes in design and/or improvements upon its products without any obligation to include these changes in any products theretofore manufactured.

No warranty, whether expressed or implied, is given or made with respect to any accessory supplied with products described above. Except to the extent prohibited by applicable law, all implied warranties made by ADJ Products, LLC in connection with this product, including warranties of merchantability or fitness, are limited in duration to the warranty period set forth above. And no warranties, whether expressed or implied, including warranties of merchantability or fitness, shall apply to this product after said period has expired. The consumer's and/or Dealer's sole remedy shall be such repair or replacement as is expressly provided above; and under no circumstances shall ADJ Products, LLC be liable for any loss or damage, direct or consequential, arising out of the use of, or inability to use, this product.

This warranty is the only written warranty applicable to ADJ Products, LLC Products and supersedes all prior warranties and written descriptions of warranty terms and conditions heretofore published.

MANUFACTURER'S LIMITED WARRANTY PERIODS:

- **Non L.E.D. Lighting Products = 1-year (365 days) Limited Warranty** (Such as: Special Effect Lighting, Intelligent Lighting, UV lighting, Strobes, Fog Machines, Bubble Machines, Mirror Balls, Par Cans, Trussing, Lighting Stands etc. excluding LED and lamps)
- **Laser Products = 1 Year (365 Days) Limited Warranty** (excluding laser diodes which have a 6 month limited warranty)
- **L.E.D. Products = 2-year (730 days) Limited Warranty** (excluding batteries which have a 180 day limited warranty). **Note: 2 Year Warranty only applies to purchases within the United States.**
- **StarTec Series = 1 Year Limited Warranty** (excluding batteries which have a 180 day limited warranty).
- **ADJ DMX Controllers = 2 Year (730 Days) Limited Warranty**

Voltage:	100V ~ 240V/50~60Hz
IP Rating:	IP65
Lamp:	Osram Sirius HRI 100W Discharge Lamp
Lamp Hours:	6,000 Hour Average Lamp Life*
Color Temperature:	9000K
Power Draw:	235W
Weight:	36 lbs./ 16.3 kgs.
Dimensions:	13.25" (L) x 8.25" (W) x 18.05" (H) 336 x 210 x 458mm
Gobos:	15 Gobos + Open
Prisms:	16 Facet Circular)
DMX Channels:	2 DMX Modes: 11 / 14
Warranty:	2 Year (730 days)

* May vary depending on several factors including but not limited to:
Environmental Conditions, Power/Voltage, Usage Patterns (On-Off Cycling), Control, and Dimming.

Please Note: Specifications and improvements in the design of this unit and this manual are subject to change.